

Thermally induced pulsation in the solid-state single-frequency diode pumped laser

IGOR PESHKO

Institute of Physics National Academy of Sciences of Ukraine, 46 Science Av., 252650, Kyiv, Ukraine.

JAN K. JABCZYŃSKI

Institute of Optoelectronics, Military University of Technology, 01-489 Warszawa, ul. Kaliskiego 2, Poland.

Slow, periodical self-modulation phenomena in the diode-pumped single-frequency Nd:YVO₄ laser with cobalt thin-film selector have been demonstrated. The pulses with duration about 1–3 s and period about 3–10 s, depending on pump power and thermo-optical properties of cavity, have been observed. The effect has been explained by the thermal changes of the cavity length connected with the difference of the heat generation rate for operating and non-operating laser.

1. Introduction

A new age of the solid-state lasers started with diode pumping technology. Because of the real absence of mechanical, thermal and spectral disturbances it becomes possible to study several subtle laser effects covered up till now by noisy properties of pumping flash-lamps. Moreover, resonant excitation of the active ion by the emission with relatively narrow spectral linewidth minimizes the number of manifold intertransitions and emphasizes main energy flows occurring in the excited solid-state medium.

The laser with optical pumping may be classified as an entropy transformer. The pumping laser diode arrays emit, as a rule, low coherent radiation with beam volume several times wider than diffraction limit and multimode spectrum linewidth of few THz. On the other hand, the diode pumped single-frequency laser operates in fundamental mode with linewidth of some kHz. Evidently, to transform low coherent light source to the system with much higher performance one has to expand some part of pump energy, usually higher than quantum defect (*i.e.*, the ratio of the difference between the pump and laser radiation photon energies to the pump photon energy). Hence, the principal limitation of laser efficiency may be estimated. In some special cases the pumping as well as output laser beam may have approximately the same wavelength, *e.g.*, InGaAsP diode operating at 1.47–1.48 μm that pumps Er:glass laser with 1.55- μm wavelength of output [1]. Quantum defect is minimal in such a case (<5%) and the laser input-output efficiency is limited by the losses connected with the entropy transformation only.

In principle, high coherent, single frequency mode of laser operation is strongly non-equilibrium state. Whenever it interacts with an environment it tends to increase the entropy. Thus, the single longitudinal mode laser shows a tendency to frequency drift over gain bandwidth resulting in changes of the waste heat generation rate. However, this excess of waste energy may be used for modification of the laser action conditions resulting in the return to the coherent, single mode state. Such a process in certain conditions, as was demonstrated in our experiments, can be periodical.

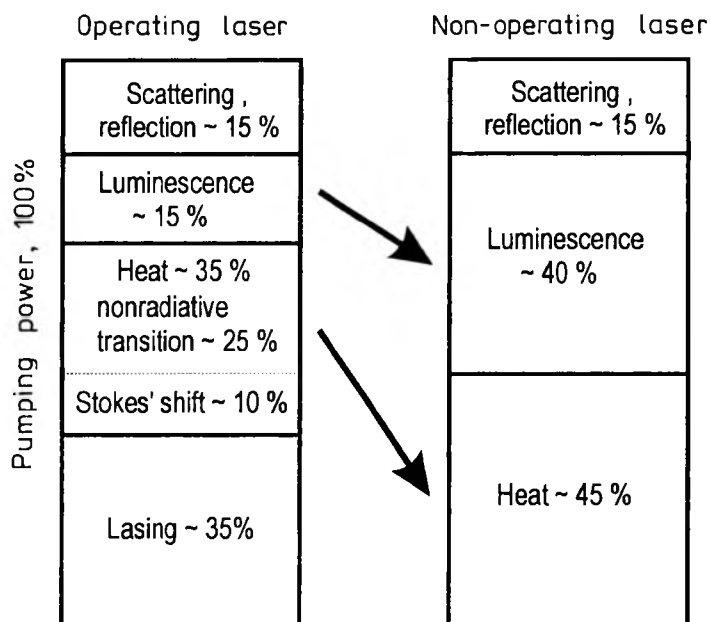

Fig. 1. Scheme of absorbed pump power partition in operating (left bar) and non-operating laser (right bar).

Above threshold, during laser action, the total absorbed pump power is distributed among several channels (see Fig. 1), namely: scattering in the cavity elements and reflection on the surfaces, volume waste heat generation by multiphonon relaxation, excited state absorption, and into stimulated emission. The same portion of the pump power is scattered during laser action as well as in excited, but non-lasing state, whereas the waste heat generation part can change because of stimulated emission absence [2], [3]. BROWN estimates in paper [2] that the difference in waste heat energy between lasing and non-lasing states is about 1–10% of absorbed pump power depending on dopant level, crystal quality, pumping level. The existence of the significant and variable thermal part of dissipated power causes changes of the thermally induced optical path differences (T-OPD) of active medium and may be observed by means of interferometric inspection of active medium by the testing laser beam (see, *e.g.*, [3]–[6]). The

T-OPD effects can be divided into: “zero-order” effect of optical elongation of active medium resulting in the changes of optical length of cavity, “first order” effect of thermal lensing resulting in changing the confocal parameter of cavity, and thermally induced higher order aberrations causing decrease of efficiency and degradation of laser beam quality. The “zero-order” thermal elongation effect may cause frequency drift and mode hopping. The “first-order” thermal lensing in a gain medium modifies space configuration of the cavity that may result in transverse mode structure variations and changes of mode matching efficiency. HARDMAN *et al.* showed in [3] that thermally induced effects (beam quality degradation, thermal lensing power) can differ significantly (about 2–4 times) between non-lasing and lasing states in the case of high brightness pumping.

However, for the low and medium pump levels (typical of low power single frequency lasers) a weak change of waste heat power (<5%) does not cause changes in the cavity configuration, thus, only “zero order” effects should be observed. Let us notice that relative elongation of cavity length even about 10^{-5} (induced by temperature change of 1–2 K) can result in one intermode space tuning for longer cavities. Such an effect is used in a single frequency microchip laser for pump power or thermal tuning [7] in the full gain bandwidth of active medium with temperature dependence of frequency of few GHz/K.

Our paper is devoted to observation of similar effect in more complicated experimental conditions, namely in metallic thin film, tuned, single frequency Nd:YVO₄ laser. The thermally induced variations of optical path in active medium resulted in regular, periodical pulsation of instantaneous output power of such a laser. In Sec. 2, the experimental results are presented. The explanation and discussion of experiments are given in the following section.

2. Experimental results

The scheme of the metallic thin film, tuned single frequency Nd:YVO₄ laser is shown in Fig. 2. The pump beam was provided by 2 W laser diode (LDT-27004) tuned to the peak of Nd:YVO₄ absorption band by the SDL 822 controller. The “a-cut” Nd doped (1 atm. %) YVO₄ crystal of $5 \times 5 \times 1$ mm³ in size was mounted in the massive brass substrate with conic hole in the center transmitting the pumping radiation. The pumping beam entered into the 1 mm-long crystal through a dichroic coating on the rear facet with 90% transmission at 0.81 μm and 99.5% reflectance at 1.06 μm. The 8 nm-thick cobalt selector was deposited on the second facet of the gain crystal placed at about 0.2 mm from the output coupler (OC) of 5% transmission. The OC was mounted on the piezotransducer that provided standing wave figure in the cavity such that initial selector position was in the vicinity of the separated standing wave node. The average output power was measured by Newport 1825-C power meter equipped with 818-SL probe. The instantaneous power variations were detected by New Focus Photoreceiver model 2001 and monitored at PC equipped with CompuScope 1012 card. Maximum cw power of single-frequency operation about 0.6 W and slope efficiency about 40% was demonstrated [8].

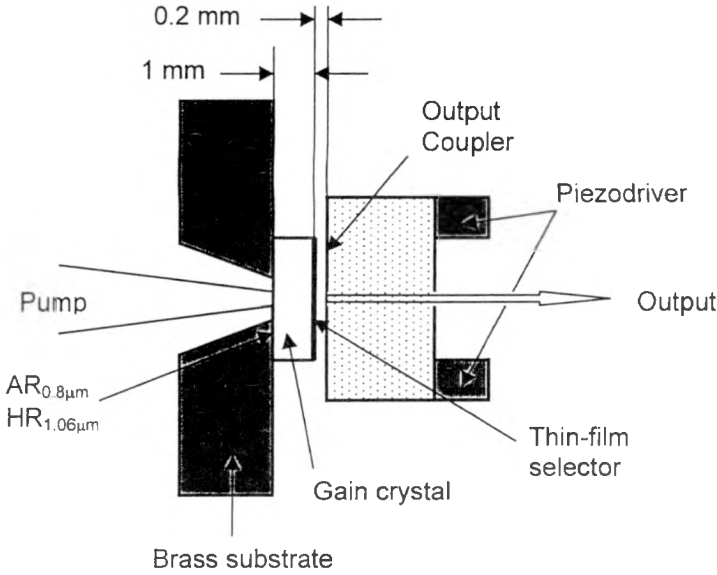

Fig. 2. Scheme of laser cavity with thin film selector deposited on the active medium facet.

The main idea of the absorbing thin film selector operation is the following. The metallic film with thickness ($\delta d \approx \lambda/100$) significantly smaller than the standing wave period is placed in the linear cavity. If a thin film plane is adjusted to the node surface area of any mode, the losses for this mode become close to zero and single longitudinal mode starts to operate. To achieve high output power the special properties of the reflective interferometer formed by the thin-film selector and the output coupler should be used. A detailed description of the interferometer with an

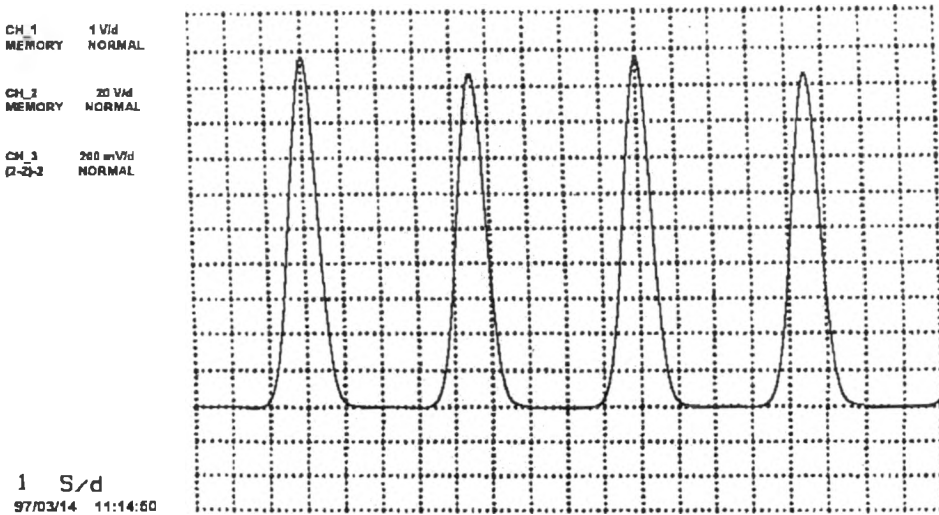

Fig. 3. Instantaneous power of thermally induced pulsation effect in the Nd:YVO₄ laser vs. time.

absorbing mirror can be found in [8], [9]. The enhance stable single frequency output it was necessary to find such a position of the OC that would cause thin film selector location in the vicinity of separated node of standing wave. However, it has been observed that at low and medium pump powers there exist special OC positions resulting in "slow" pulsed regime demonstrated in Fig. 3. The period and pulse duration depend in these cases on the pump power level and thermo-optical properties of the cavity.

3. Discussion

The self-pulsation regime of operation can be explained by periodical modulation of variable losses of thin film selector caused by the thermally induced changes of optical length of active medium. Let us assume that the thin-film selector is placed between the two nodes of neighbouring modes for pump level slightly below threshold. At this moment, the maximum possible portion of pump power is transformed to the heat and temperature of the crystal increases. Because of the thermal elongation of active medium one of the positions of nodes moves to the absorbing thin-film location and the losses for this mode fall down. In Figure 4,

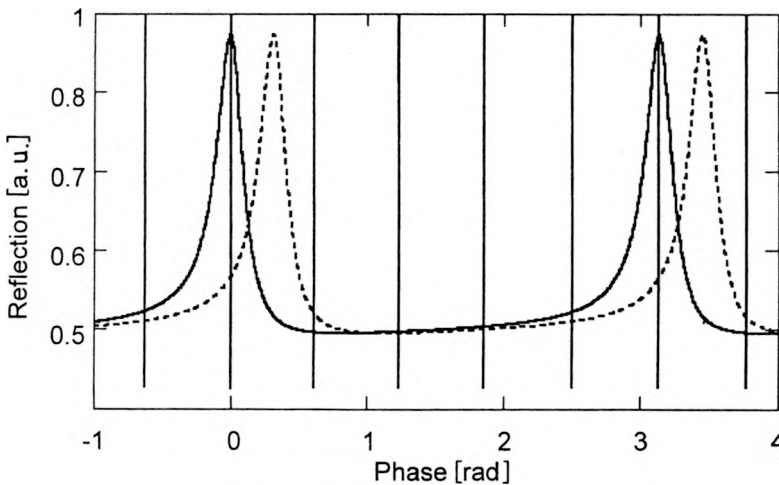

Fig. 4. Phase characteristics of reflective interferometer formed by metallic thin film—output coupler: operating laser — solid line, non-operating laser — dashed line.

relative positions of the modes and the absorbing interferometer reflection peaks are shown. The solid curve demonstrates resonance position that provides the laser operation. The laser starts to operate in the single-frequency regime. At maximum output power the waste heat generation rate becomes minimum and crystal temperature starts to decrease causing a decrease of optical length of crystal. Further, the thin-film location "comes out" from the node position and interrupts the laser emission process (dashed curve in Fig. 4). After the break-off laser action the

temperature rises up again and the process repeats. In such a way, the instantaneous power, spatial and temporal coherence of output beam oscillate periodically. The spectral width of emission switches from 200 GHz (fluorescence bandwidth of crystal) to some kHz (laser single-frequency linewidth). The period of oscillation and pulse duration depend on pump power and thermo-optical properties of the cavity. The characteristic time of this process of few seconds is much longer than laser relaxation period and decay times (several tens of microseconds), thus we concluded that the observed pulsation is caused mainly by slow thermo-optical changes of cavity parameters.

The distance between two neighbouring nodes at selector location is $\lambda l/2L \sim 50$ nm, where l is the interferometer length, L is the cavity length, and λ is laser emission wavelength. To move the selector from the node location of the operating mode to the position that introduces maximum losses one has to change the optical length of the cavity to half of this inter-node distance. Thermal elongation on 25 nm of the 2-mm cavity length means 10^{-5} relative elongation of the gain crystal. To achieve such elongation one has to change crystal temperature to $\Delta T \sim 2$ K. From calorimetric consideration the increment of internal energy ΔE resulting in such a temperature difference is given by $\Delta E = C_T \rho V \Delta T$, where $C_T = 630 \text{ J} \cdot \text{kg}^{-1} \cdot \text{K}^{-1}$ is YVO₄ crystal heat capacity, $\rho = 4.22 \text{ g} \cdot \text{cm}^{-3}$ is material density. From these data it results that $\Delta E \approx 60$ mJ. The period of the observed pulsation process was about 5 s (see Fig. 3). Hence, the average magnitude of heat power modulation ΔP is about 12 mW, *i.e.*, about 1% of incident pump power. This relationship is valid as long as time of heat dissipation from the mode volume is much longer than time of change of the optical cavity length. The waste heat power increment ΔQ needed to enforce thermally induced oscillations can be determined also from thermo-optical point of view. Assuming that increment of optical path $\text{OPD} = \chi_{\text{tot}} \Delta Q / K$, where K denotes thermal conductivity and χ_{tot} denotes generalized dispersion of active medium (see, *e.g.*, [4]) we can estimate the magnitude of heat increment. Hence, we have found that in order to cause thermally induced OPD of $\lambda/50$ in the YVO₄ crystal, a heat power increment of about 10 mW is needed. This result is consistent with that obtained in calorimetric estimations. It should be noted that the exact analysis of such an effect requires detailed information about averaged pump diameter, parameters of heat contacts, *etc.* Our aim of this paper was only to show the existence of such an effect. There exist so many unknown factors (*e.g.*, efficiencies of heat conversion channels, influence of pump intensity, thermal stability of cavity base, properties of thermal contacts) that more detailed analysis was impossible at the time of experiments. However, we think that quantitative analysis of this effect is possible and can be applied as a complementary method in a study of heat conversion effects and determination of thermo-optical properties of active media.

4. Summary

The pulses with half-intensity duration about 1–3 s and period about 3–10 s were observed in continuously diode-pumped single-frequency Nd:YVO₄ laser with

cobalt thin-film selector. The effect of slow periodical self-modulation has been explained by the changes of the cavity length connected with the different heat generation rate for operating and non-operating laser.

Acknowledgements – The authors would like to thank J. Firak from the Institute of Optoelectronics, Military University of Technology, Warsaw, Poland, for fruitful discussion and technical support. This work was partly supported by the Polish Committee for Scientific Research (KBN) under the grant PBZ 2183/T1197/10.

References

- [1] KIMURA Y., SUZUKI K., NAKAZAWA M., *Opt. Lett.* **14** (1989), 999.
- [2] BROWN D. C., *IEEE J. Quantum Electron.* **34** (1998), 560.
- [3] HARDMAN P. J., CLARKSON W. A., FRIEL G. J., POLLNAU M., HANNA D. C., *IEEE J. Quantum Electron.* **35** (1999), 647.
- [4] PFISTNER C., WEBER R., WEBER H. P., MERAZZI S., GRUBER R., *IEEE J. Quantum Electron.* **30** (1994), 1605.
- [5] JABCZYŃSKI J. K., KOPCZYŃSKI K., SZCZEŚNIAK A., *Opt. Eng.* **35** (1996), 3572.
- [6] SKELDON M. D., SAAGER R. B., SEKA W., *IEEE J. Quantum Electron.* **33** (1999), 381.
- [7] ZAYHOWSKI J. J., KESZENHEIMER J. A., *IEEE J. Quantum Electron.* **28** (1992), 1118.
- [8] JABCZYŃSKI J. K., PESHKO I., FIRAK J., *Appl. Opt.* **36** (1997), 2484.
- [9] PESHKO I., JABCZYŃSKI J. K., FIRAK J., *IEEE J. Quantum Electron.* **33** (1997), 1417.

Received May 20, 1999